



Intelligent Infrared CO2 Module (Model: MH-Z19)

User's Manual

(Version: 1.0)

Valid from: 2015.03.03

Zhengzhou Winsen Electronics Technology Co., Ltd

ISO9001 certificated company

Statement

This manual's copyright belongs to Zhengzhou Winsen Electronics Technology Co., LTD. Without the written permission, any part of this manual shall not be copied, translated, stored in database or retrieval system, also can't spread through electronic, copying, record ways.

Thanks for purchasing our product. In order to let customers use it better and reduce the faults caused by misuse, please read the manual carefully and operate it correctly in accordance with the instructions. If users disobey the terms or remove, disassemble, change the components inside of the sensor, we shall not be responsible for the loss.

The specific such as color, appearance, sizes &etc., please in kind prevail.

We are devoting ourselves to products development and technical innovation, so we reserve the right to improve the products without notice. Please confirm it is the valid version before using this manual. At the same time, users' comments on optimized using way are welcome.

Please keep the manual properly, in order to get help if you have questions during the usage in the future.

Zhengzhou Winsen Electronics Technology CO., LTD.

2015.03.03

MH-Z19 NDIR CO2 Module

1. Profile



MH-Z19 NDIR infrared gas module is a common type, small size sensor, using non-dispersive infrared (NDIR) principle to detect the existence of CO₂ in the air, with good selectivity, non-oxygen dependent and long life. Built-in temperature sensor can do temperature compensation; and it has UART output and PWM output. It is developed by the tight integration of mature infrared absorbing gas detection technology, precision optical circuit design and superior circuit design.

2. Applications

MH-Z19 NDIR infrared gas module is widely used in the HVAC refrigeration and indoor air quality monitoring.

3. Main Functions and Features

- High sensitivity, high resolution
- Low power consumption
- Output modes: UART and PWM wave
- Temperature compensation, excellent linear output
- Good stability
- Long lifespan
- Anti-water vapor interference
- No poisoning

4. Technical Parameters and Structure

Product Model	MH-Z19
Target Gas	CO2
Working voltage	3.6 ~ 5.5 V DC
Average current	< 18 mA
Interface level	3.3 V
Measuring range	0 ~ 0.5% VOL optional (refer to Table 2)
Output signal	UART PWM
Preheat time	3 min
Reponse Time	T ₉₀ < 60 s
Working temperature	0 ~ 50 °C
Working humidity	0 ~ 95% RH (No condensation)
Dimension	33 mm×20 mm×9 mm (L×W×H)
Weight	21 g
Lifespan	> 5 years

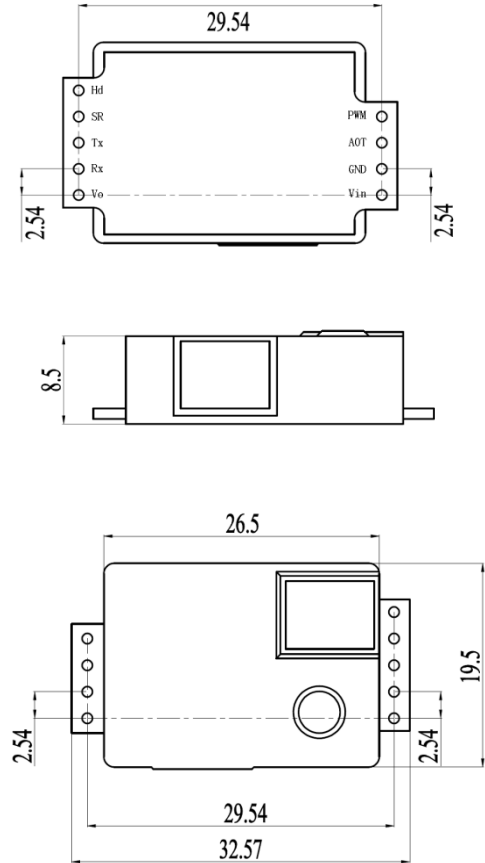

Table 1 Main Technical Parameters

Figure 1 Structure

Target Gas	Formula	Measuring Range	Accuracy	Remark
Carbon Dioxide (CO2)	CO ₂	0~2000 ppm	± (50ppm+5% reading value)	Temperature compensation
		0~5000 ppm		Temperature compensation

Table 2 Measuring Range and Accuracy

5. Pins

PIN	Description
Pin 6	Vin (voltage input)
Pin 7	GND
Pin 1	Vout (output voltage 3.3V, output current lower than 10mA)
Pin 9	PWM
Pin 5	HD (zero calibration, low level above 7 seconds) (Factory Reserved)
Pin 2	UART (RXD) 0~3.3V digital input
Pin 3	UART (TXD) 0~3.3V digital output
Pin 4	SR (Factory Reserved)
Pin 8	AOT (Factory Reserved)



Table 3 Definition for Pins

Figure 2 Pins Diagram

6. Application Circuit

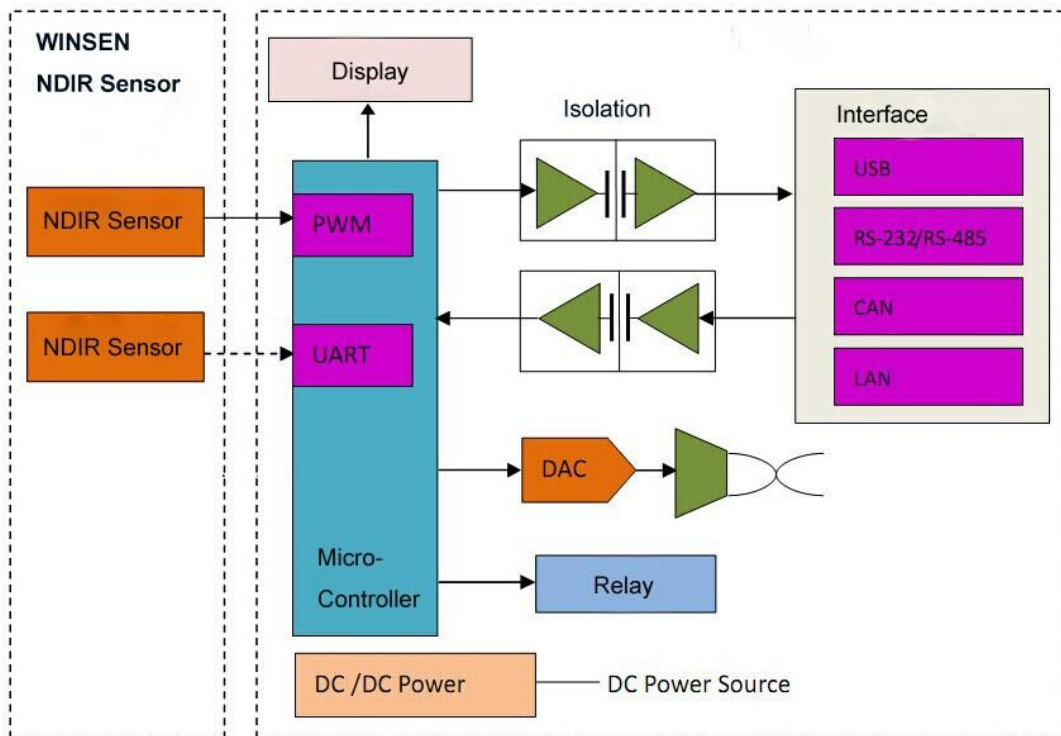

Figure 3 Application Circuit

7. Output Data Reading

7.1 PWM output (taking PWM output of 0~2000ppm detection range as example)

CO2 output range: 0ppm-2000ppm

Cycle: 1004ms ± 5%

High level output for beginning: 2ms ± 5%

Middle of cycle: 1000ms ± 5%

Low level output for ending: 2ms ± 5%

Account formula for CO2 concentration which gets through PWM,

$$C_{ppm} = 2000 \times (T_H - 2ms) / (T_H + T_L - 4ms)$$

Among:

C_{ppm} is calculated CO2 concentration, unit is ppm;

T_H is time for high level during an output cycle;

T_L is time for low level during an output cycle.

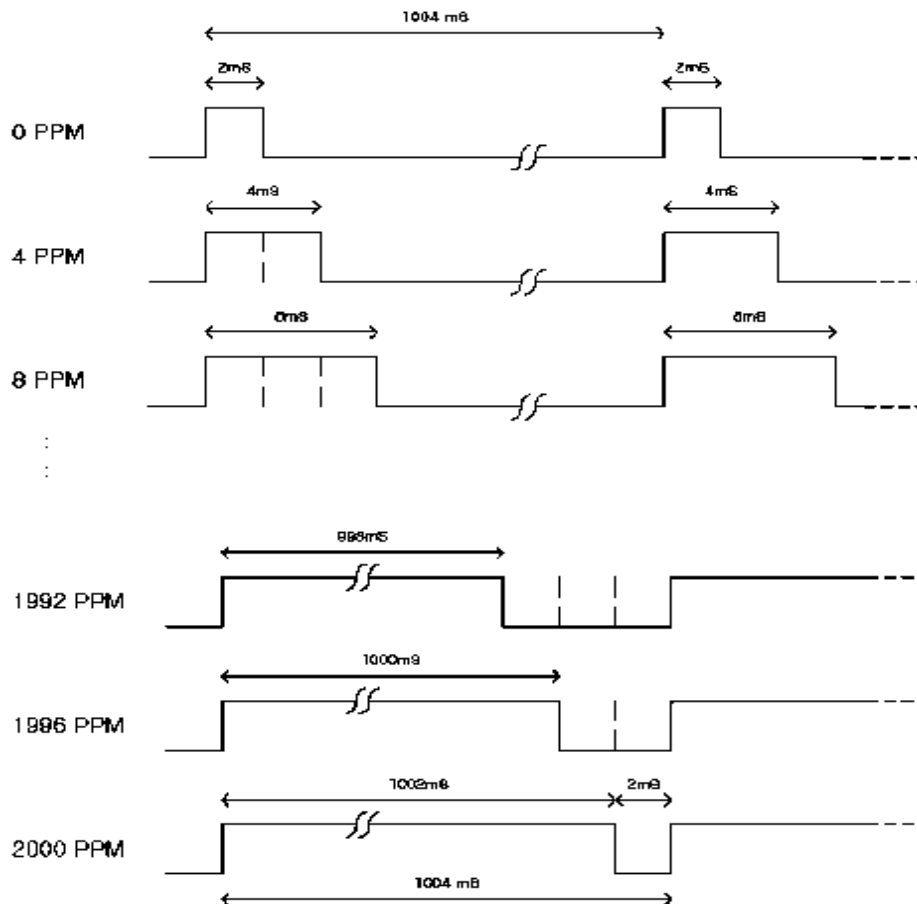

Figure 4 PWM Output

7.2 Transmit Data

Vin-5V power

GND- Power Ground

RXD connect sensor TXD

TXD connect sensor RXD

You can read gas concentration via UART directly, no need to calculate.

7.2.1 Communication Protocol

A. General Settings

Baud rate	9600
Date byte	8 byte
Stop byte	1byte
Parity (check bits)	no

B. Command

Each command or return:

Contains 9 bytes (byte 0 ~ 8)

starting byte fixed to 0xFF

command contains sensor number (factory default is 0 x01)

end with proof test value Checksum (refer to below Calibrate and Calculate method)

Command List

0x86	Gas Concentration
0x87	Calibrate zero point (ZERO)
0x88	Calibrate span point (SPAN)

Gas concentration reading

Send command								
Byte0	Byte1	Byte2	Byte3	Byte4	Byte5	Byte6	Byte7	Byte8
Starting byte	Sensor No.	command	-	-	-	-	-	Check value
0xFF	0x01	0x86	0x00	0x00	0x00	0x00	0x00	0x79

Return value

Return								
Byte0	Byte1	Byte2	Byte3	Byte4	Byte5	Byte6	Byte7	Byte8
Starting byte	command	High level concentration	Low level concentration	-	-	-	-	Check value

0XFF	0x86	0x02	0x60	0x47	0x00	0x00	0x00	0xD1
------	------	------	------	------	------	------	------	------

Gas concentration= high level *256+low level

Calibrate zero point

Send command								
Byte0	Byte1	Byte2	Byte3	Byte4	Byte5	Byte6	Byte7	Byte8
Starting byte	Sensor No.	command	-	-	-	-	-	Check value
0XFF	0x01	0x87	0x00	0x00	0x00	0x00	0x00	0x78

No return value

Calibrate span point

Send command								
Byte0	Byte1	Byte2	Byte3	Byte4	Byte5	Byte6	Byte7	Byte8
Starting byte	Sensor No.	command	high level span point	Low level span point	-	-	-	Check value
0XFF	0x01	0x88	0x07	0xD0	0x00	0x00	0x00	0xA0

No return value

C. Calibrate and Calculate

The checksum = (invert (byte 1 +... + 7)) + 1

Gas concentration reading

Send command								
Byte0	Byte1	Byte2	Byte3	Byte4	Byte5	Byte6	Byte7	Byte8
Starting byte	Sensor No.	command	-	-	-	-	-	Check value
0XFF	0x01	0x86	0x00	0x00	0x00	0x00	0x00	0x79

Except byte 0 ,add the other bytes together

$$0x1 + 0x86 + 0 + 0 + 0 + 0 + 0 = 0x87$$

Get the value from the first step, then invert it.

$$0xff - 0x87 = 0x78$$

The second value plus one

$$0x78 + 0x01 = 0x79$$

7.2.2 Program: C language

```
char getChecksum(char *packet)
{
    char i, checksum;
    for( i = 1; i < 8; i++)
    {
        checksum += packet[i];
    }
    checksum = 0xff - checksum;
    checksum += 1;
    return checksum;
}
```

8. Notes

8.1 Do not use the sensor in the high dusty environment for long time.

8.2 Please use the sensor with correct power supply.

Zhengzhou Winsen Electronics Technology Co., Ltd

Add.: NO.299 Jin Suo Road, National Hi-Tech Zone,
Zhengzhou, 450001 China

Tel.: 0086-371-67169097 67169670

Fax:0371-60932988

E-mail:sales@winsensor.com