

Battery Voltage: 5-30V
Output is $\pm V_{batt}/2$

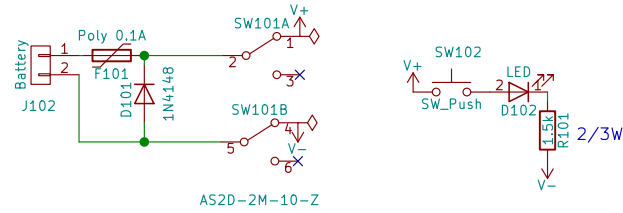

- Mounting Holes
- ×1 J103
 - ×1 J104
 - ×1 J105
 - ×1 J106

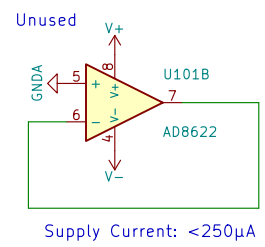
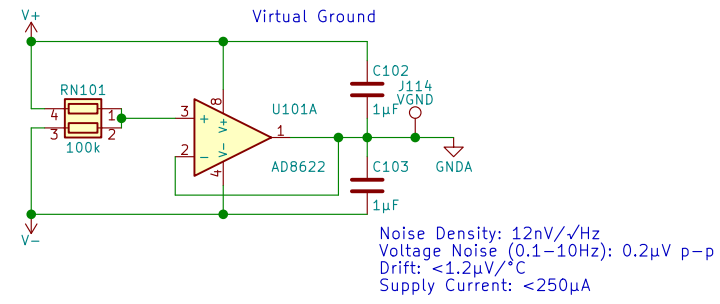
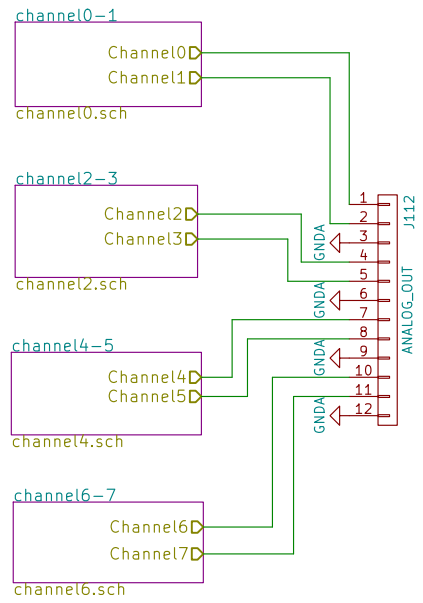

Monadnock Systems	
Sheet: /	
File: bmi-8ch.sch	
Title: Polymer Sensor Amplifier	
Size: USLetter	Date: 2017-03-31
KiCad E.D.A. kicad 4.0.6	Rev: AB
	Id: 1/5

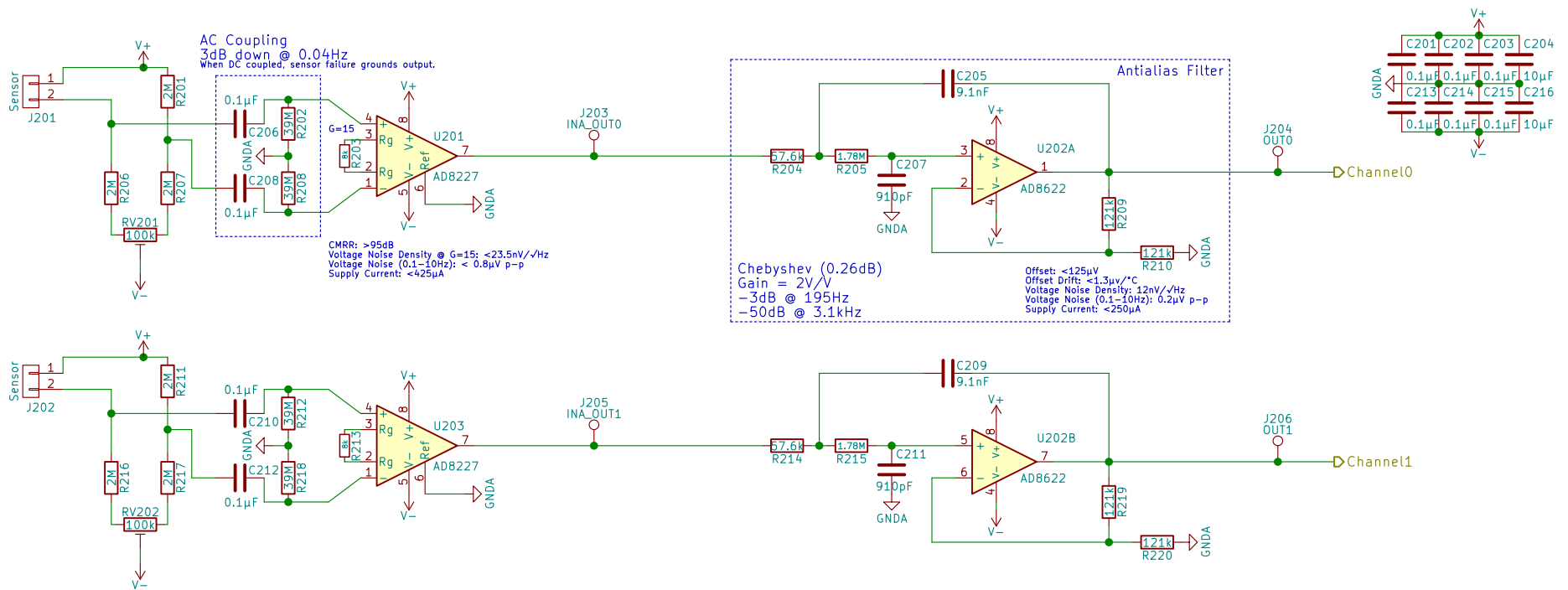

Notes:

- R203, R213: 0.1%
- Other R: 1%
- C205, C206, C207, C208, C209, C210, C211, C212: 50V NP0
- Bypass Caps: 50V X7R X5R

Assumptions:

- (Initial) DAQ is MCC USB-1208FS (available at BMI)
- 11-bit, max 6250 S/sec for each channel; sequential
- Target Bandwidth: 195Hz
- Sampling Rate 6240 S/s
- Sensor resistance 2MΩ
- Respiration motion changes sensor resistance by $\pm 10\%$
- Sensor resistance changes with handling; would require at least per-subject trimming if DC coupled.

Problems:

- USB-1208FS has fixed single-ended range of $\pm 10V$
- Drop in upgrade to USB-1608FS (16bit and variable range)
- Mitigated initially by running on 18V via two 9V batteries.
- R202, R208, R212, R218; 39M only available in thick film.
- More (slightly) 1/f noise and $\pm 5\%$ accuracy.
- AC coupling isn't optional in this design. Rhodri keen to try AC route first; add cost / complexity later if needed.

Open Questions:

1. AC vs DC Coupling:
 - AC: no trimming, better UX, better tempco, cheaper
 - DC: captures all low-frequency signal that may be of interest
2. Use chopper amps in signal path: Probably bad
 - Lower total noise for *extremely* small bandwidths (<math>< 5Hz</math>?)
 - Lower offset (if DC coupled)

Monadnock Systems

Sheet: /channel0-1/
File: channel0.sch

Title: Input Channel 0 & 1

Size: USLetter Date: 2017-03-31
KiCad E.D.A. kicad 4.0.6

Rev: AB
Id: 2/5

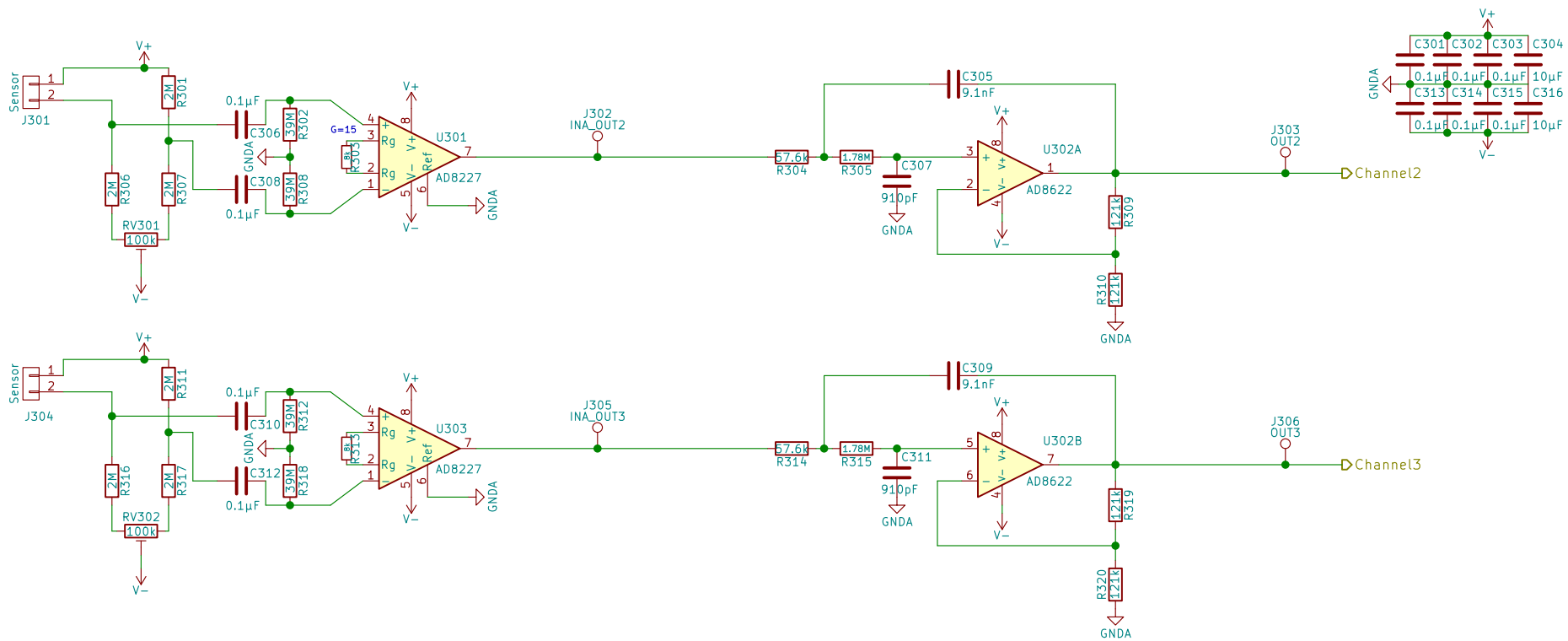

Notes:

- R303, R313: 0.1%
- Other R: 1%
- C305, C306, C307, C308, C309, C310, C311, C312: 50V NP0
- Bypass Caps: 50V X7R or X5R

Monadnock Systems	
Sheet: /channel2-3/ File: channel2.sch	
Title: Input Channel 2 & 3	
Size: USLetter	Date: 2017-03-31
KiCad E.D.A. kicad 4.0.6	Rev: AB Id: 3/5

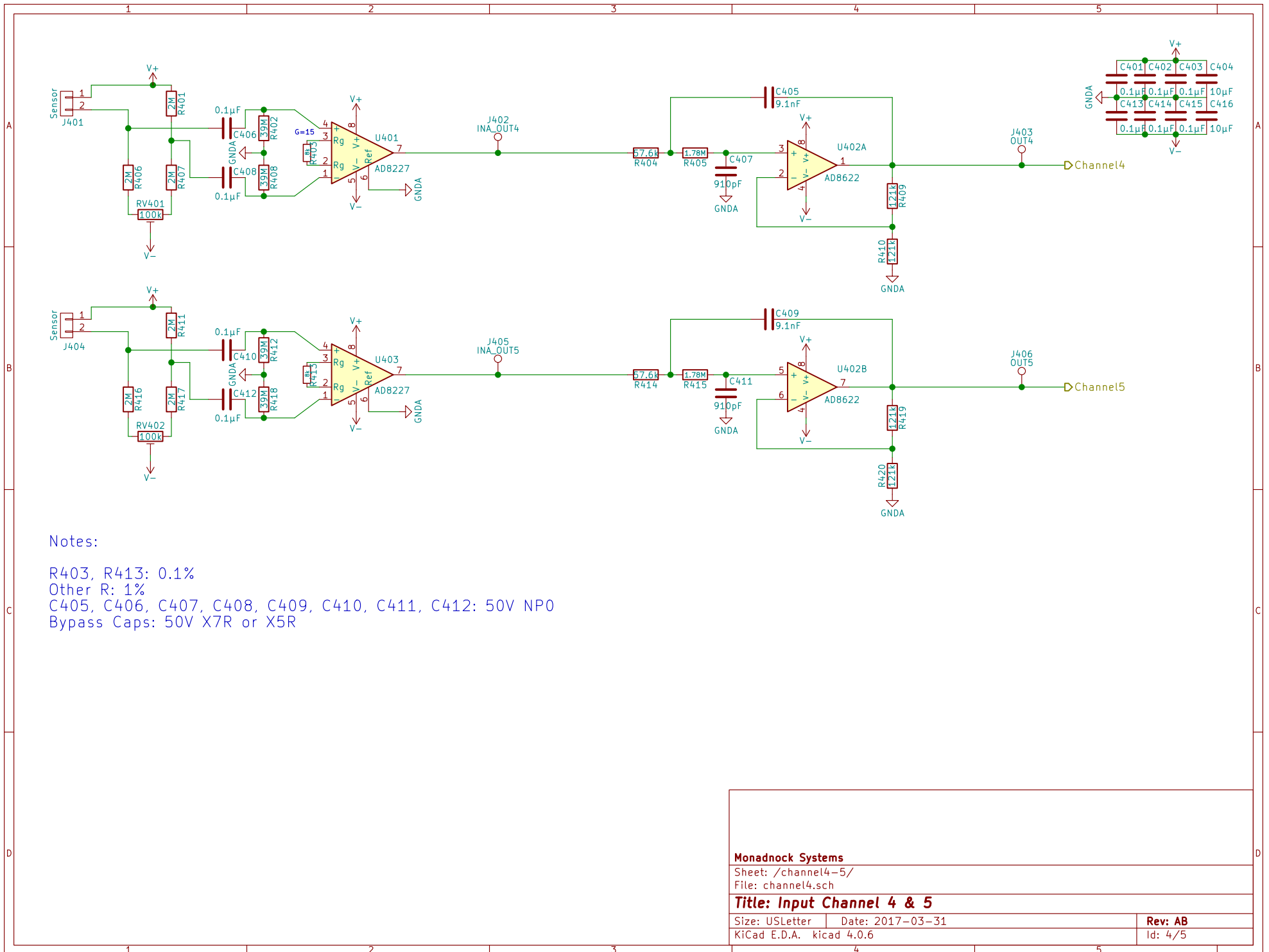

Notes:

- R403, R413: 0.1%
- Other R: 1%
- C405, C406, C407, C408, C409, C410, C411, C412: 50V NP0
- Bypass Caps: 50V X7R or X5R

Monadnock Systems	
Sheet: /channel4-5/ File: channel4.sch	
Title: Input Channel 4 & 5	
Size: USLetter	Date: 2017-03-31
KiCad E.D.A. kicad 4.0.6	Rev: AB Id: 4/5

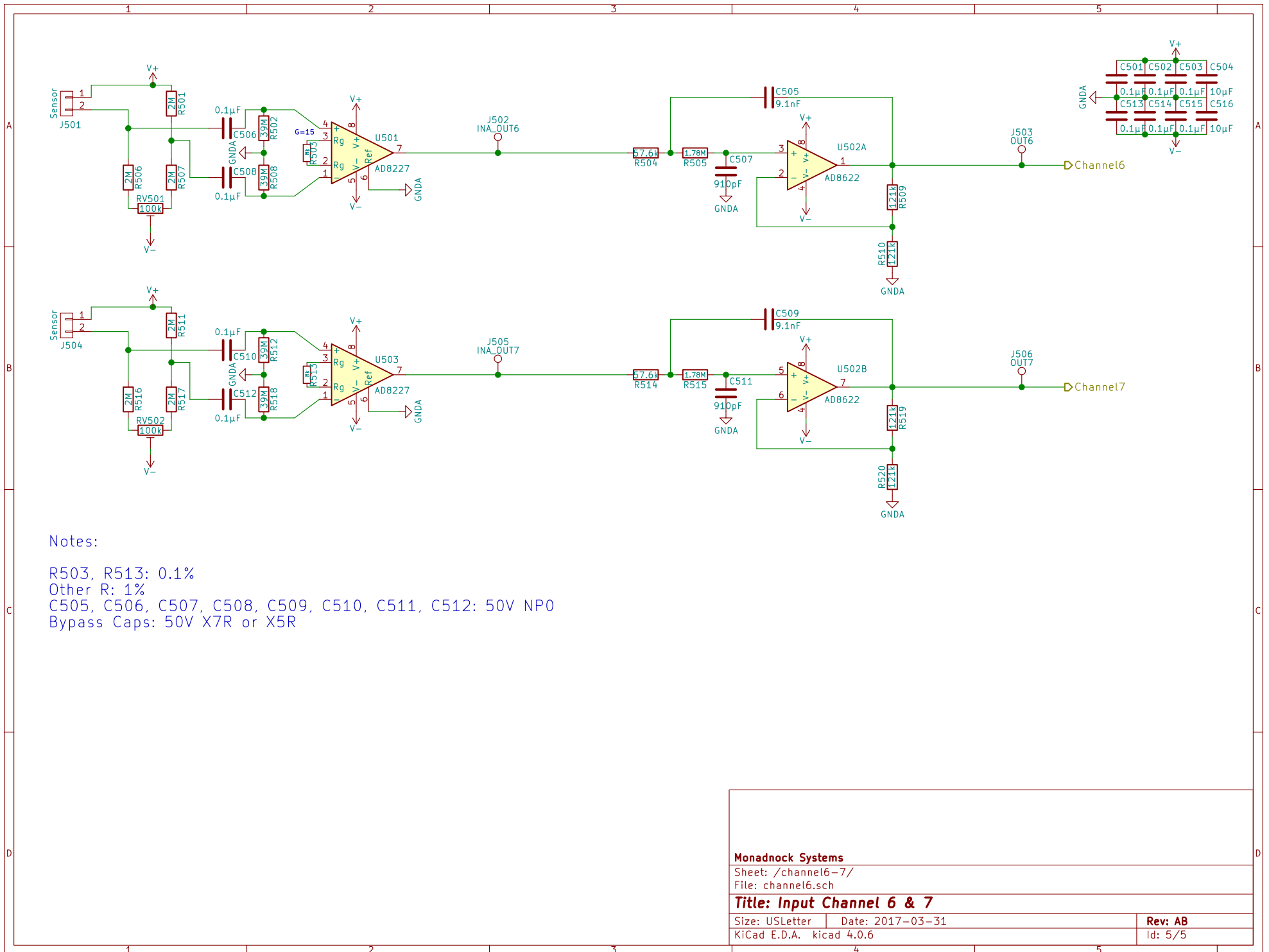

Notes:

- R503, R513: 0.1%
- Other R: 1%
- C505, C506, C507, C508, C509, C510, C511, C512: 50V NP0
- Bypass Caps: 50V X7R or X5R

Monadnock Systems	
Sheet: /channel6-7/ File: channel6.sch	
Title: Input Channel 6 & 7	
Size: USLetter	Date: 2017-03-31
KiCad E.D.A. kicad 4.0.6	Rev: AB Id: 5/5